

## HOW TO ORDER A SPLIT FINISH

---

**Split Finish sales are final and cannot be returned, altered, or canceled once submitted.**

Prior to ordering please contact customer service at [wscustomerpo@waterstoneco.com](mailto:wscustomerpo@waterstoneco.com) and request the sign off sheet for your model. The sign off sheet must be signed and dated and returned with your order.

### WATERSTONE DESIGNED STANDARD SPLIT FINISHES

**(Standard lead times apply)**

Faucet can be split using any combination of the standard finishes listed below. For pricing add 10% to the higher list price of the 2 finishes.

**Chrome - CH**

**Classic Bronze - CLZ**

**Matte Black - MB**

**Polished Nickel - PN**

**Satin Nickel - SN**

**Unlacquered Polished Brass - UPB**



### HOW TO DESIGNATE A SPLIT FINISH FAUCET WHEN ORDERING

Take the model number and add both finishes to the suffix starting with the **Primary finish** followed by the **Accent finish**. For Matte Black (MB) and Classic Bronze (CLZ), it would be **10103-MB\_CLZ**. If you wanted Classic Bronze (CLZ) and Polished Nickel (PN) it would be **10103-CLZ\_PN**. For all split finish designs click "Split Finishes" in the top menu of our home page on [www.waterstoneco.com](http://www.waterstoneco.com)

# SPLIT FINISHES - BATH



## SHOWER

□ WHITE = PRIMARY FINISH  
■ GRAY = ACCENT FINISH

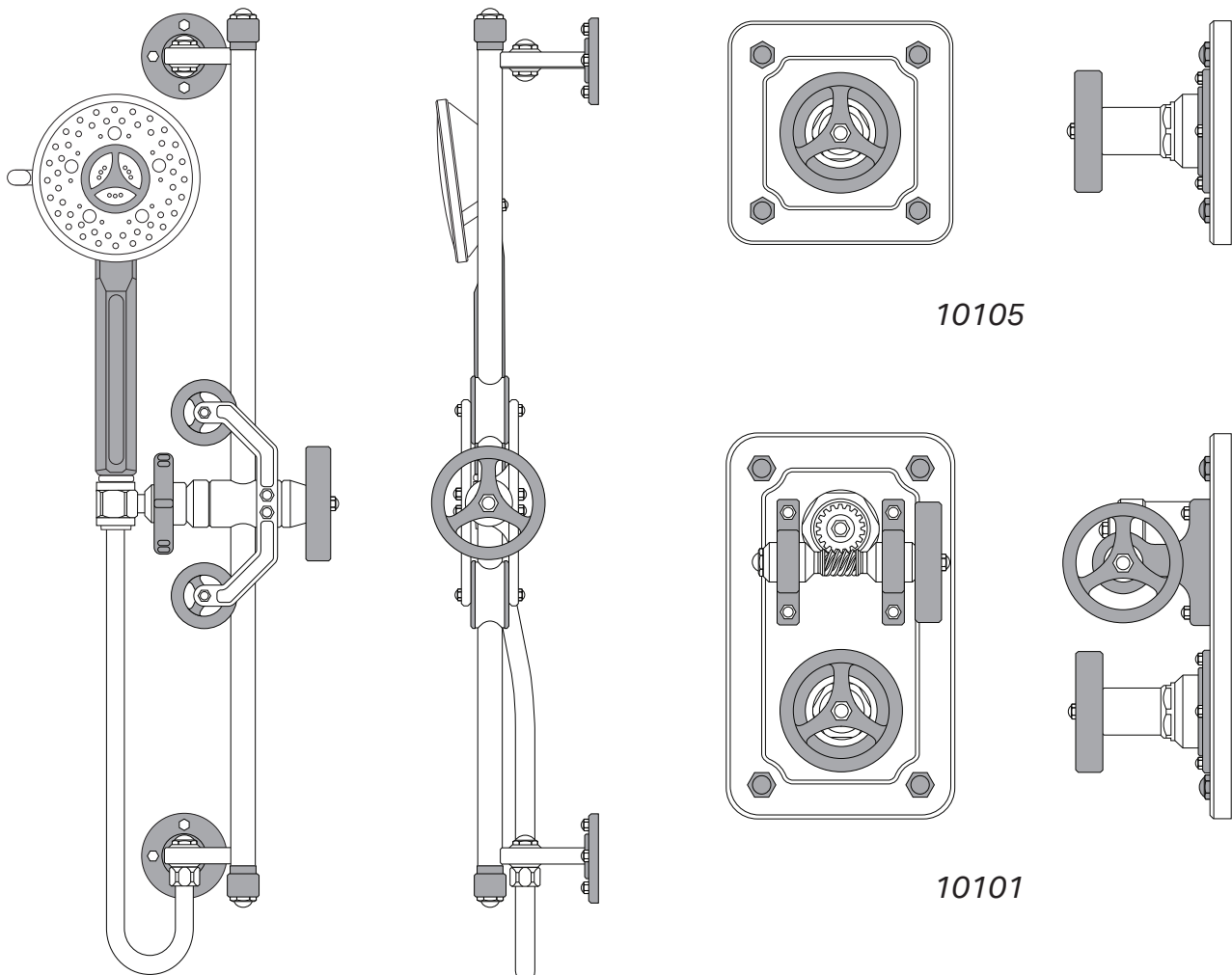
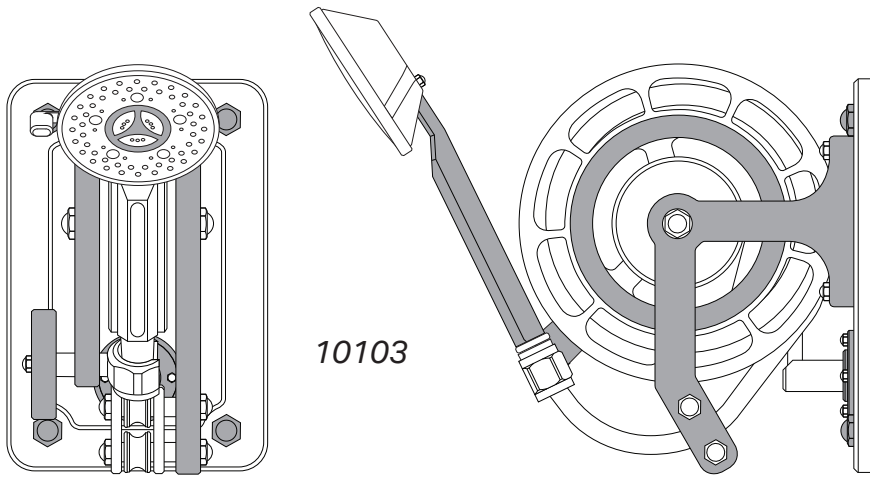

# SPLIT FINISHES - BATH



## SHOWER

□ WHITE = PRIMARY FINISH  
■ GRAY = ACCENT FINISH

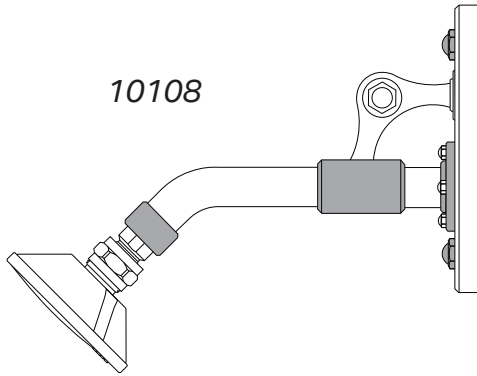
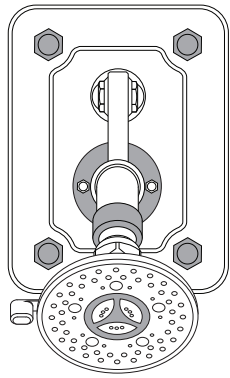

## TUB

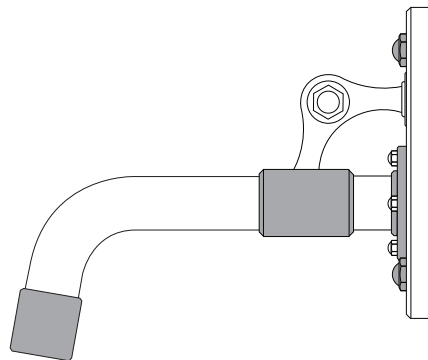
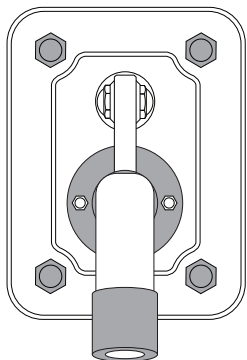
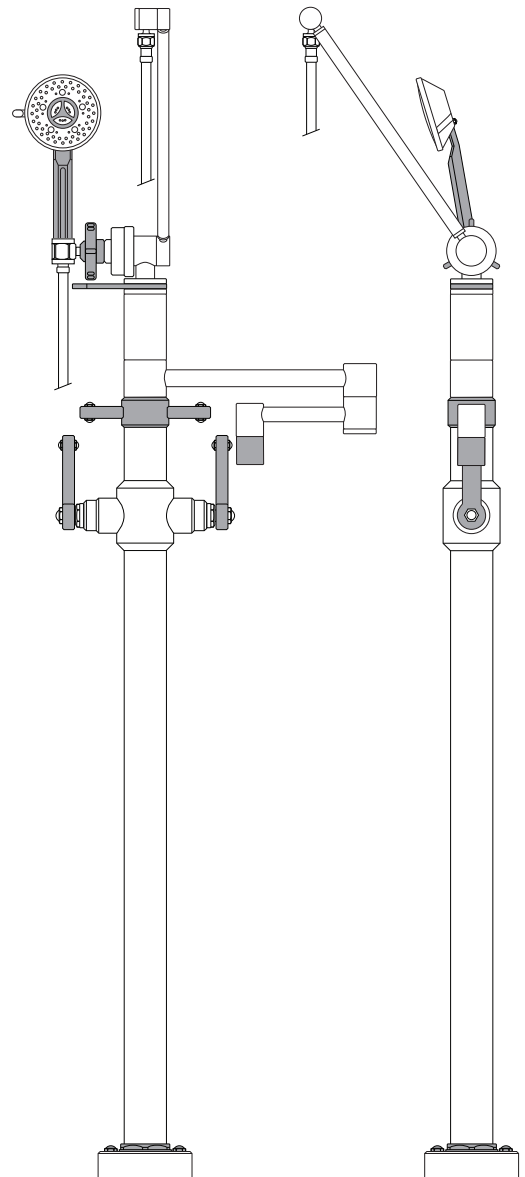
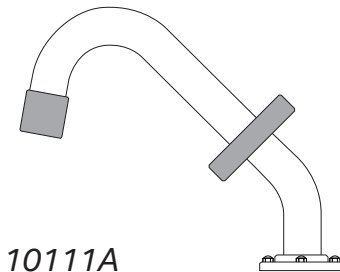
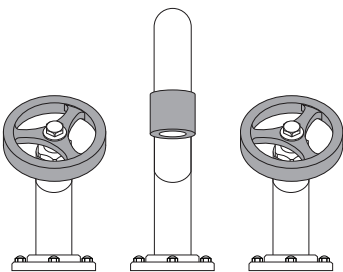
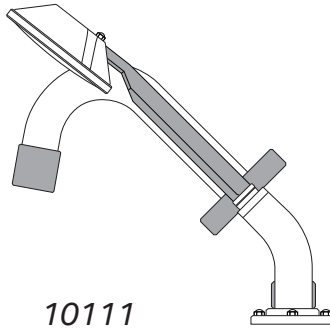
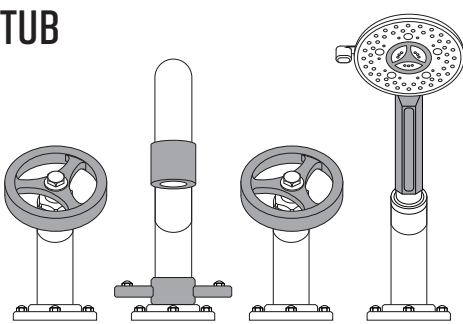

10110

# SPLIT FINISHES - BATH



## LAVATORY FAUCET

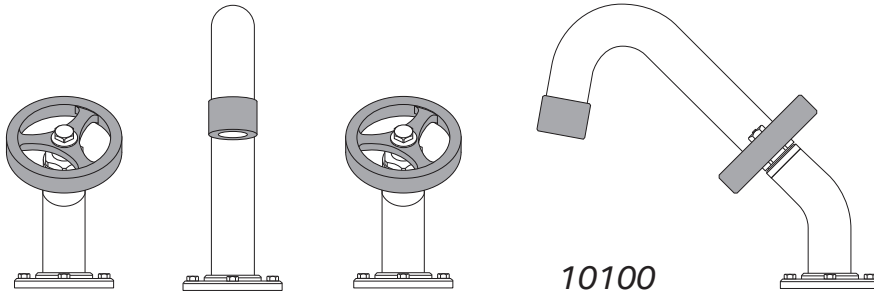

□ WHITE = PRIMARY FINISH  
■ GRAY = ACCENT FINISH

## ACCESSORIES

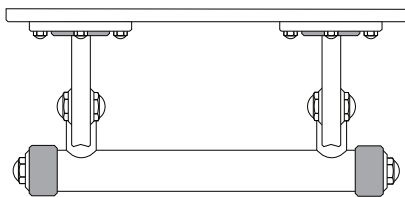

10160

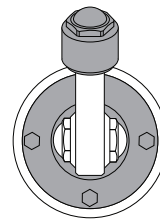

10150

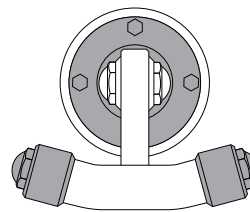
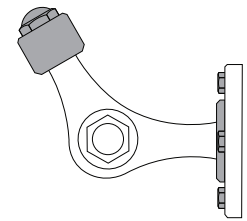

10155



10165, 10170, 10175, 10180



888-304-0660 • [www.waterstoneco.com](http://www.waterstoneco.com)