

**BEFORE YOU BEGIN YOUR INSTALLATION:**



Turn off water supply.

**REQUIRED TOOLS:**



Adjustable Wrench



Pliers



Channel Locks

**1.**

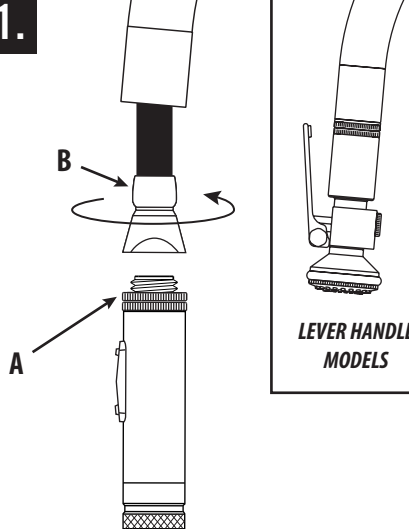

**LEVER HANDLE MODELS**

Turn off water supply. Hold the top ring of the knurl swivel assembly (A) with pliers. Use an adjustable wrench and loosen latch connector (B). Remove nozzle.

**2.**

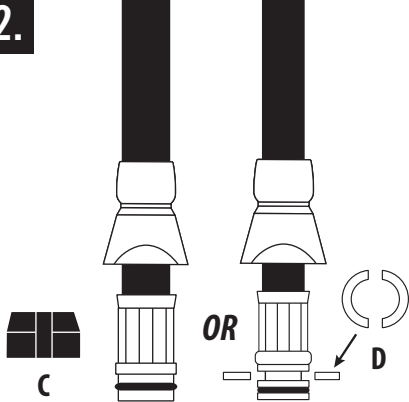

Slide latch connector up to expose compressor collar. Depending on hose configuration, there may be either a black collar (C) or two metal half circles (D). Carefully pry black collar off neck of hose connection. The half circles are loose and will just fall out.

**3.**

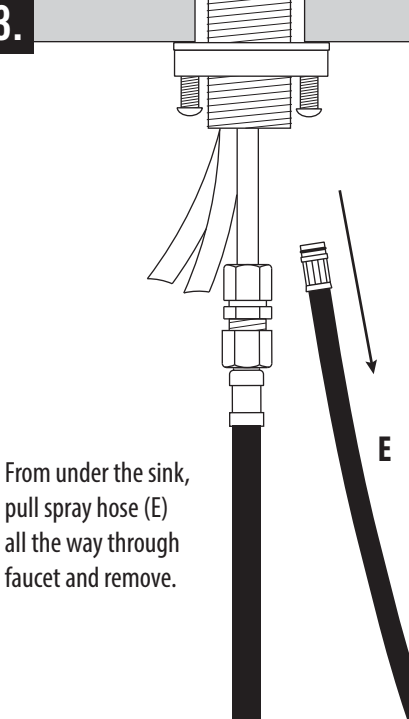

From under the sink, pull spray hose (E) all the way through faucet and remove.

**4.**

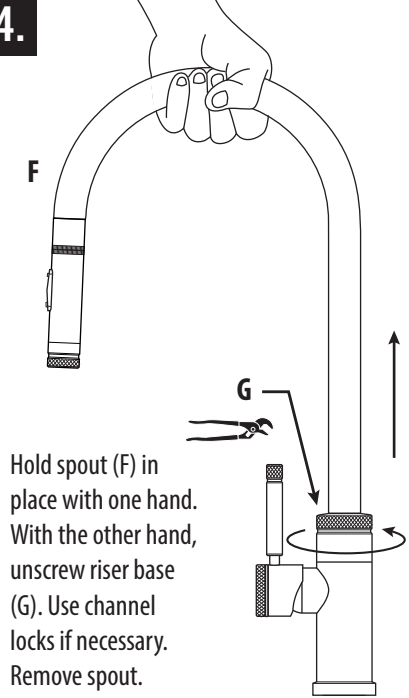

Hold spout (F) in place with one hand. With the other hand, unscrew riser base (G). Use channel locks if necessary. Remove spout.

**5.**

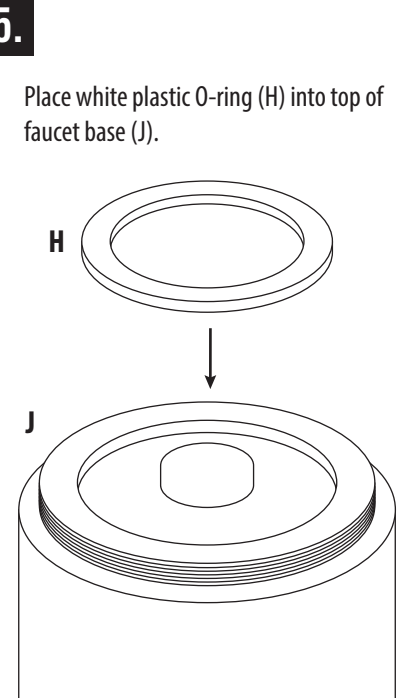

Place white plastic O-ring (H) into top of faucet base (J).

**6.**

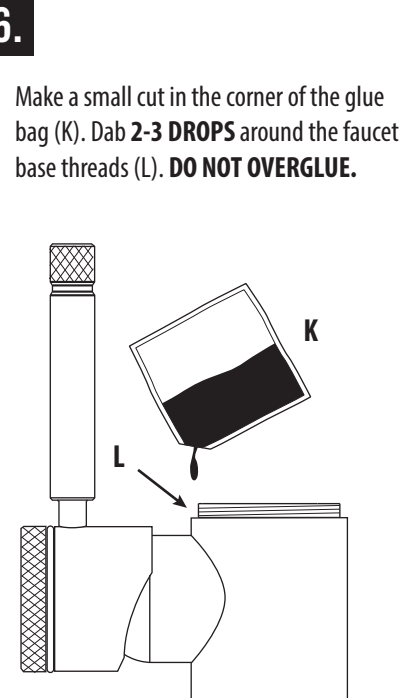

Make a small cut in the corner of the glue bag (K). Dab **2-3 DROPS** around the faucet base threads (L). **DO NOT OVERGLUE.**

7.

Install new spout. Tighten riser base snugly by hand. **DO NOT** use channel locks.

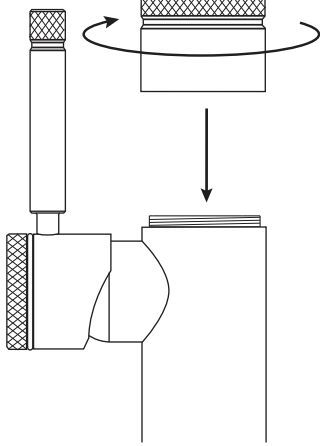

8.

From under the sink, insert spray hose into base of faucet. Slide hose up through faucet until end of hose is exposed.

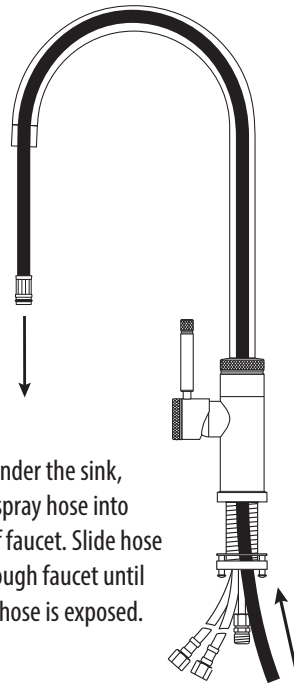

9.

Slide latch connector over hose connection and up onto hose.

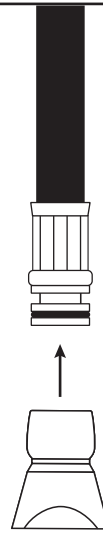

10.

Depending on hose configuration, either snap black collar onto hose connection, or slide the half circles onto each side. Hold in place and slide latch connector down, covering entire hose connection.

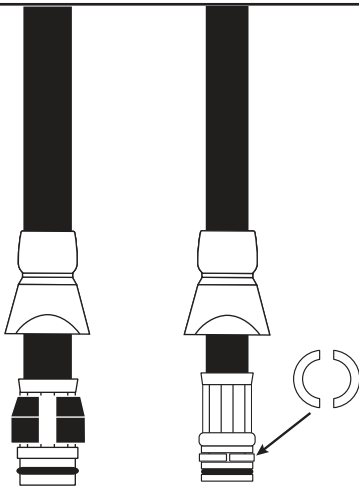

11.

Using pliers and an adjustable wrench, attach latch connector to nozzle. Tighten until snug. Turn on water supply and check for leaks.

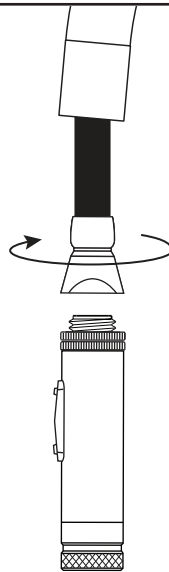

**NOTE: NEW SPOUT IS ENGINEERED WITH A ANTI-ROCKING DESIGN. THE SPOUT SWIVEL WILL BE STIFFER, BUT STABLE.**

★ MADE IN THE USA ★

1-888-304-0660 • 951-304-0520

www.waterstoneco.com

VEN-038-RK-IPSR Rev. B