



BAR FAUCET VALVE CARTRIDGE REPLACEMENT

BEFORE YOU BEGIN YOUR INSTALLATION:



Turn off water supply.

REQUIRED TOOLS:



Adjustable Wrench



1/8 Hex Key Wrench



3/8" 6-Point
Socket Wrench



Pliers

TRADITIONAL BAR FAUCET MODEL #S I300, I350, I500, I550, I800, I850

Place a sandwich bag over cover screws (A) to avoid scratching finish. Unscrew with socket wrench and remove. Remove handles (B) from valves (C). Wiggle handles back and forth to help remove. Unscrew valve cartridges and remove. The adapter sleeve may or may not come out. Replace sleeves if needed. Insert new cartridges into valve bodies (D). Tighten until snug. Slide handles back over valve splines. Handle position should be in the closed position and vertical. Replace valve cover screws and hand tighten. Place sandwich bag back over cover screws and tighten with socket drive. **DON'T** use pliers.

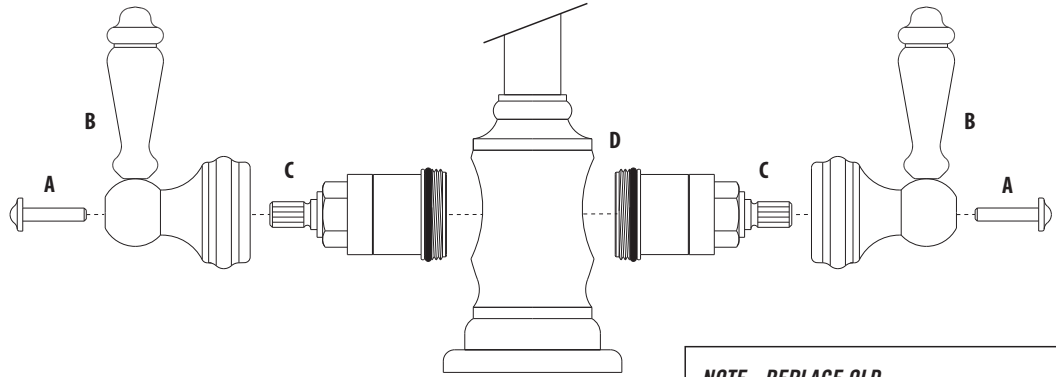

NOTE - REPLACE OLD ADAPTER SLEEVE IF NEEDED

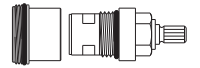

CONTEMPORARY BAR FAUCET MODEL #S I600, I625, 2500

Wrap handles (A) with a cloth to protect finish, loosen with pliers and remove. Using a 1/8 hex key wrench, loosen set screws (B) 1 or 2 turns. Remove valve covers (C) from valves (D) by pulling straight out. Wiggle cover back and forth to help remove. Unscrew cartridges on both sides and remove. The adapter sleeve may or may not come out. Replace sleeves if needed. Insert new cartridges into valve bodies (E) and tighten until snug. Slide valve covers back over valve splines. Handle position should be in the closed position and vertical. Tighten set screws securely and connect handles.

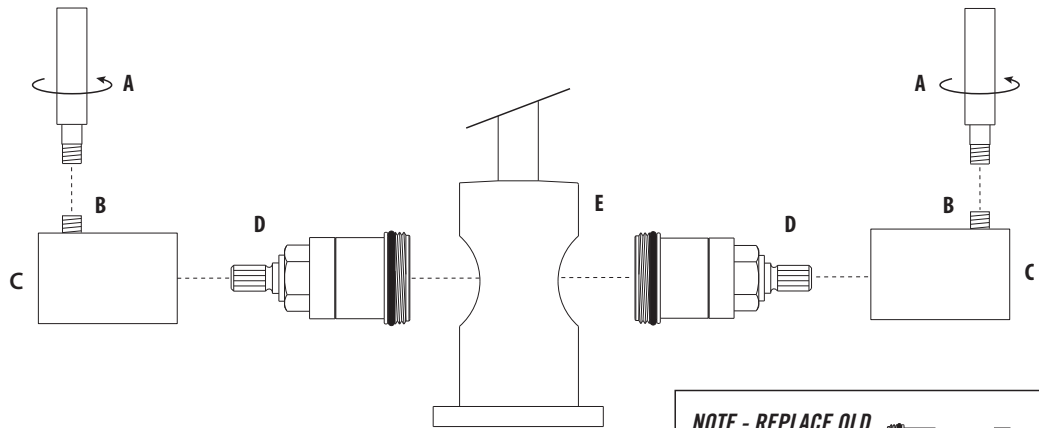

NOTE - REPLACE OLD ADAPTER SLEEVE IF NEEDED

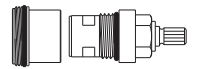

★ MADE IN THE USA ★

1-888-304-0660 • 951-304-0520

www.waterstoneco.com

VEN-038-RK-BFRV Rev. D